

WHELEN[®]

ENGINEERING COMPANY INC.

51 Winthrop Road
Chester, Connecticut 06412-0684
Phone: (860) 526-9504
Fax: (860) 526-4078
Internet: www.whelen.com
Sales e-mail: autosale@whelen.com
Canadian Sales e-mail: autocan@whelen.com
Customer Service e-mail: custserv@whelen.com

Installation Manual 900 Series LED Lighthouse

Safety First

This document provides all the necessary information to allow your Whelen product to be properly and safely installed. Before beginning the installation and/or operation of your new product, the installation technician and operator must read this manual completely. Important information is contained herein that could prevent serious injury or damage.

- **Proper installation of this product requires the installer to have a good understanding of automotive electronics, systems and procedures.**
- **If mounting this product requires drilling holes, the installer MUST be sure that no vehicle components or other vital parts could be damaged by the drilling process. Check both sides of the mounting surface before drilling begins. Also de-burr any holes and remove any metal shards or remnants. Install grommets into all wire passage holes.**
- **If this manual states that this product may be mounted with suction cups, magnets, tape or Velcro[®], clean the mounting surface with a 50/50 mix of isopropyl alcohol and water and dry thoroughly.**
- **Do not install this product or route any wires in the deployment area of your air bag. Equipment mounted or located in the air bag deployment area will damage or reduce the effectiveness of the air bag, or become a projectile that could cause serious personal injury or death. Refer to your vehicle owner's manual for the air bag deployment area. The User/Installer assumes full responsibility to determine proper mounting location, based on providing ultimate safety to all passengers inside the vehicle.**
- **For this product to operate at optimum efficiency, a good electrical connection to chassis ground must be made. The recommended procedure requires the product ground wire to be connected directly to the NEGATIVE (-) battery post.**
- **If this product uses a remote device to activate or control this product, make sure that this control is located in an area that allows both the vehicle and the control to be operated safely in any driving condition.**
- **Do not attempt to activate or control this device in a hazardous driving situation.**
- **This product contains either strobe light(s), halogen light(s), high-intensity LEDs or a combination of these lights. Do not stare directly into these lights. Momentary blindness and/or eye damage could result.**
- **Use only soap and water to clean the outer lens. Use of other chemicals could result in premature lens cracking (crazing) and discoloration. Lenses in this condition have significantly reduced effectiveness and should be replaced immediately. Inspect and operate this product regularly to confirm its proper operation and mounting condition. Do not use a pressure washer to clean this product.**
- **It is recommended that these instructions be stored in a safe place and referred to when performing maintenance and/or reinstallation of this product.**
- **FAILURE TO FOLLOW THESE SAFETY PRECAUTIONS AND INSTRUCTIONS COULD RESULT IN DAMAGE TO THE PRODUCT OR VEHICLE AND/OR SERIOUS INJURY TO YOU AND YOUR PASSENGERS!**

For warranty information regarding this product, visit www.whelen.com/warranty

IMPORTANT NOTICE! This product has been designed for improved visibility. Prior to installing this product on any vehicle, check your state motor vehicle codes to confirm that this product complies with any and all state statutes.

Typical Mounting Style:

- Using the dimensions from the diagram below, mark off and drill the two 5/16" diameter vent tube holes and the 1" center wire hole into the mounting surface. Make sure lighthouse will not interfere with existing equipment and be aware of any items on the opposite side of the mounting surface.

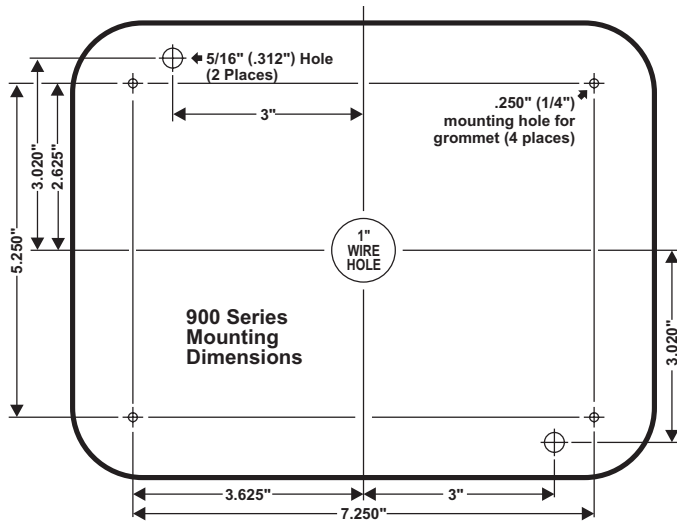

- Insert the two vent tubes extending from the rear of the lighthouse into their holes making sure that the lighthouse is oriented as shown. Using a scribe or similar tool, mark off the 4 mounting holes.
- Using a .250 drill bit drill the four mounting holes and install the 4 supplied grommets. Install a grommet (customer supplied) into the 1" wire hole.

WARNING! All customer supplied wires that connect to the positive terminal of the battery must be sized to supply at least 125% of the maximum operating current and FUSED at the battery to carry the load. DO NOT USE CIRCUIT BREAKERS WITH THIS PRODUCT!

- Using appropriately sized wires, run the lighthouse wires to their connections (see wiring). Fuse the +12VDC connections at 3 Amps and test the operation of the lighthouse before securing it to the vehicle.
- Position lighthouse components onto mounting surface and secure the lighthouse to the vehicle using four #8 x 1 1/2" sheet metal screws.

This product draws significantly less current than a standard incandescent automotive bulb. If your flasher does not operate properly, it may be necessary to replace your existing flasher module with a Whelen 3TERM flasher module. Contact your sales representative for specific vehicle application.

Wiring:

ARROW / WIDE ANGLE / FLOOD

Wire Color	Function
Colored This wire color will be whatever the color of its LED is when light is switched on.	+12 VDC
Black	Ground
White/Violet	Scan-Lock™

BRAKE / TAIL / TURN

Wire Color	Function
Yellow	Stop/Turn (+ 12 VDC)
Brown	Taillight (+12 VDC)
White	Ground
Wht/Vio	Scan-Lock™

SPLIT / SMT

Wire Color	Function
Yellow or Red	+12 VDC, Control Wire 1
Yellow or Red	+12 VDC, Control Wire 2
Black	Ground

COMPARTMENT LIGHT

Wire Color	Function
White	Positive (+) High Power
Grey	Positive (+) Low Power
Black	Ground

BACK-UP

Wire Color	Function
Colored This wire color will be whatever the color of its LED is when light is switched on.	+12 VDC
Black	Ground

Scan-Lock™ (White/Violet)

WARNING: Pattern selection requires the LEDs to be turned on. Do not look directly at the LEDs while the unit is on.

TO CHANGE PATTERNS: Apply +12 volts to the WHITE/VIOLET wire for less than 1 second and release to cycle forward to the next available pattern. Apply +12 volts to the WHITE/VIOLET wire for more than 1 second and release to cycle back to the previous pattern.

TO CHANGE DEFAULT PATTERN: When the desired pattern is displayed, allow it to run for more than 5 seconds. The lighthouse will now display this pattern when initially activated.

TO RESTORE FACTORY DEFAULT PATTERN: With the power to the lighthouse off, apply +12 volts to the WHITE/VIOLET wire. Now turn power to the lighthouse on. The factory default pattern should now be displayed.

A Normally Open momentary switch can be used to control Scan-Lock.

Flash Patterns: SignalAlert™ 75 > SignalAlert 150 > SingleFlash 375 > SingleFlash 150 > SingleFlash 75 > SingleFlash 150 > DoubleFlash 150 > DoubleFlash 75 > CometFlash® 75 > ActionFlash™ > ModuFlash™ > ComAlert™ > ActionScan™ > SignalAlert Steady > Steady (Brake) **Brake Patterns:** SignalAlert Steady > Steady Brake **SYNC Patterns:** SignalAlert 75 simultaneous - 75 FPM > SignalAlert 75 alternating - 75 FPM **Arrow Patterns:** Sequence to Solid 150 FPM > Sequence to Solid 80 FPM > Sequence to Solid-Steady On: Fast > Sequence to Solid-Steady On: Slow > SignalAlert™ To Steady On > Steady On **Dual Color Patterns:** SingleFlash 680 *alternating* > SingleFlash 240 *alternating* > Singleflash 120 *alternating* > SingleFlash 150 *simultaneous* > DoubleFlash 240 *alternating* > DoubleFlash 120 *alternating* > DoubleFlash 150 *simultaneous* > CometFlash 120 *alternating* > CometFlash 120 *simultaneous* > ActionFlash *alternating* > ActionFlash *alternating-simultaneous* > ModuFlash™ *alternating* > ModuFlash™ *simultaneous* > SignalAlert 120 *alternating* > SignalAlert 100 *simultaneous* > ActionScan *alternating-simultaneous* > Action Single, 4-110 FPM-2-65 FPM > CH1 Steady-CH2 SF120 > CH1 Steady-CH2 Action Single > CH1 Steady-CH2 CometFlash® 120 > Ch1 Steady / CH2 FastAction

IMPORTANT! Before returning this vehicle to active service, visually confirm the proper operation of this product, as well as all vehicle components/equipment.

IMPORTANT WARNING!
CAUTION! DO NOT LOOK DIRECTLY AT THESE LED'S WHILE THEY ARE ON. MOMENTARY BLINDNESS AND/OR EYE DAMAGE COULD RESULT!

PART NUMBER KEY:

0 1 - 0 6 8 3 7 3 8

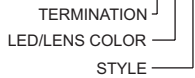

TERMINATION

- 0 = NONE
- 1 = DEUTSCH
- LED/LENS COLOR**
- A = AMBER-AMBER
- B = BLUE-BLUE
- C = WHITE-CLEAR
- G = GREEN-GREEN
- R = RED-RED
- 1 = AMBER-CLEAR
- 2 = BLUE-CLEAR
- 4 = GREEN-CLEAR
- 5 = RED-CLEAR
- S = AMB-AMB-AMB

- K = RED-AMB-RED-AMB
- W = RED-RED-RED
- 6 = AMB-AMB-CLEAR
- 7 = RED-AMB-CLEAR
- 8 = RED-RED-CLEAR

STYLE

- 2 = B-T / MIN
- 3 = ARROW
- 5 = WIDE ANGLE
- 6 = FLOOD
- B = B-T / MAX
- 9 = COMPARTMENT LIGHT
- N = B-T / CERTIFIED

- TERMINATION**
- 0 = NONE
 - 1 = DEUTSCH

OPTIONAL FLANGE KIT / 900 SERIES

QTY	ITEM	PART NUMBER	DESCRIPTION
*		01-0462945-01	FLANGE KIT with SEAL
1	A	11-783130-002	FLANGE with SEAL
1	B	38-0481440-00	FLANGE GASKET

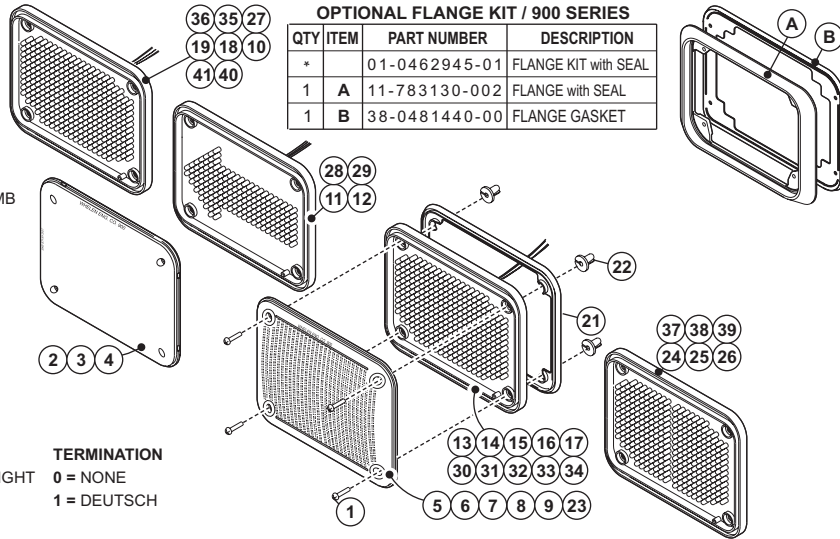

QTY	QTY	QTY	QTY	QTY	QTY	QTY	QTY	QTY	QTY	QTY	QTY	QTY	QTY	QTY	ITEM	PART NUMBER	DESCRIPTION	
															*	01-06837382R_	ASSY / LIGHTHEAD 900 LED B/T/T / MIN / RED	
															*	01-06837383A_	LIGHTHEAD 900 LED ARROW / AMBER	
														*	01-06837383R_	LIGHTHEAD 900 LED ARROW / RED		
														*	01-06837385A_	LIGHTHEAD 900 LED WIDE ANGLE / AMBER		
														*	01-06837385B_	LIGHTHEAD 900 LED WIDE ANGLE / BLUE		
														*	01-06837385C_	LIGHTHEAD 900 LED WIDE ANGLE / WHITE		
														*	01-06837385G_	LIGHTHEAD 900 LED WIDE ANGLE / GREEN		
														*	01-06837385R_	LIGHTHEAD 900 LED WIDE ANGLE / RED		
														*	01-06837386C_	LIGHTHEAD 900 LED FLOOD - WHITE		
														*	01-0683738BR_	LIGHTHEAD 900 LED B/T/T / MAX / RED		
														*	01-06837385S_	LIGHTHEAD 900 LED WIDE ANGLE - AMBER-AMBER		
														*	01-068373857_	LIGHTHEAD 900 LED WIDE ANGLE - RED-AMBER		
														*	01-06837385W_	LIGHTHEAD 900 LED WIDE ANGLE / RED-RED		
														*	01-06837389C_	LIGHTHEAD 900 LED COMPARTMENT LIGHT		
														*	01-0683738NR_	LIGHTHEAD 900 LED B/T/T CERTIFIED / RED		
4	4	4	4	4	4	4	4	4	4	4	4	4	4	4	1	15-081416-240	SCREW / #8 X 1 1/2" PPHSMS	
-	-	-	-	-	-	-	-	-	-	-	-	-	-	-	1	2	68-1182268-10	LENS / NON OPTIC / AMBER
-	-	-	-	-	-	-	-	-	-	-	-	-	-	-	1	3	68-1182268-30	LENS / NON OPTIC / CLEAR
1	-	-	-	-	1	-	-	-	-	-	-	-	-	-	1	4	68-1182268-50	LENS / NON OPTIC / RED
-	-	-	-	1	-	-	-	-	-	-	-	-	-	-	1	5	68-1183542-10	LENS / OPTIC / AMBER
-	-	-	-	-	-	-	-	-	-	-	-	-	-	-	1	6	68-1183542-20	LENS / OPTIC / BLUE
-	1	-	1	-	-	-	-	-	-	-	-	-	-	-	1	7	68-1183542-30	LENS / OPTIC / CLEAR
-	-	-	-	-	-	-	-	-	-	-	-	-	-	-	1	8	68-1183542-40	LENS / OPTIC / GREEN
-	-	1	-	-	-	-	-	-	-	-	-	-	-	-	1	9	68-1183542-50	LENS / OPTIC / RED
-	-	-	-	-	-	-	-	-	-	-	-	-	-	-	A/R	10	01-0283754-52	SUB ASSY / LED B/T/T / MIN / RED
-	-	-	-	-	-	-	-	-	-	-	-	-	-	-	A/R	11	01-0283754-13	SUB ASSY / LED ARROW / AMBER
-	-	-	-	-	-	-	-	-	-	-	-	-	-	-	A/R	12	01-0283754-53	SUB ASSY / LED ARROW / RED
-	-	-	-	-	-	-	-	-	-	-	-	-	-	-	A/R	13	01-0283754-15	SUB ASSY / LED WIDE ANGLE / AMBER
-	-	-	-	-	-	-	-	-	-	-	-	-	-	-	A/R	14	01-0283754-25	SUB ASSY / LED WIDE ANGLE / BLUE
-	-	-	-	-	-	-	-	-	-	-	-	-	-	-	A/R	15	01-0283754-35	SUB ASSY / LED WIDE ANGLE / WHITE
-	-	-	-	-	-	-	-	-	-	-	-	-	-	-	A/R	16	01-0283754-45	SUB ASSY / LED WIDE ANGLE / GREEN
-	-	-	-	-	-	-	-	-	-	-	-	-	-	-	A/R	17	01-0283754-55	SUB ASSY / LED WIDE ANGLE / RED
-	-	-	-	-	-	-	-	-	-	-	-	-	-	-	A/R	18	01-0283754-36	SUB ASSY / LED FLOOD / WHITE
-	-	-	-	-	-	-	-	-	-	-	-	-	-	-	A/R	19	01-0283754-5B	SUB ASSY / LED B/T/T / MAX / RED
1	1	1	1	1	1	1	1	1	1	1	1	1	1	1	1	20	10-0522908-__	LABEL / LED LIGHTHEAD
1	1	1	1	1	1	1	1	1	1	1	1	1	1	1	1	21	38-0481690-00	GASKET
4	4	4	4	4	4	4	4	4	4	4	4	4	4	4	4	22	21-1708080603	SCREW GROMMET / ROUND HOLE
-	-	-	A/R	-	-	-	-	-	-	-	-	-	-	-	-	23	02-0363407-AR	LENS / OPTIC / AMBER-RED
-	-	-	A/R	-	-	-	-	-	-	-	-	-	-	-	-	24	01-0283754-A5	SUB ASSY / LED WIDE ANGLE / AMBER-AMBER
-	-	-	A/R	-	-	-	-	-	-	-	-	-	-	-	-	25	01-0283754-K5	SUB ASSY / LED WIDE ANGLE / RED-AMBER
-	-	-	A/R	-	-	-	-	-	-	-	-	-	-	-	-	26	01-0283754-R5	SUB ASSY / LED WIDE ANGLE / RED-RED
-	-	-	-	-	-	-	-	-	-	-	-	-	-	-	A/R	27	02-0383754152	SUB ASSY / LED B/T/T / MIN / RED / DEUTSCH
-	-	-	-	-	-	-	-	-	-	-	-	-	-	-	A/R	28	02-0383754113	SUB ASSY / LED ARROW / AMBER / DEUTSCH
-	-	-	-	-	-	-	-	-	-	-	-	-	-	-	A/R	29	02-0383754153	SUB ASSY / LED ARROW / RED / DEUTSCH
-	-	-	-	-	-	-	-	-	-	-	-	-	-	-	A/R	30	02-0383754115	SUB ASSY / LED WIDE ANGLE / AMBER / DEUTSCH
-	-	-	-	-	-	-	-	-	-	-	-	-	-	-	A/R	31	02-0383754125	SUB ASSY / LED WIDE ANGLE / BLUE / DEUTSCH
-	-	-	-	-	-	-	-	-	-	-	-	-	-	-	A/R	32	02-0383754135	SUB ASSY / LED WIDE ANGLE / WHITE / DEUTSCH
-	-	-	-	-	-	-	-	-	-	-	-	-	-	-	A/R	33	02-0383754145	SUB ASSY / LED WIDE ANGLE / GREEN / DEUTSCH
-	-	-	-	-	-	-	-	-	-	-	-	-	-	-	A/R	34	02-0383754155	SUB ASSY / LED WIDE ANGLE / RED / DEUTSCH
-	-	-	-	-	-	-	-	-	-	-	-	-	-	-	A/R	35	02-0383754136	SUB ASSY / LED FLOOD / WHITE / DEUTSCH
-	-	-	-	-	-	-	-	-	-	-	-	-	-	-	A/R	36	02-038375415B	SUB ASSY / LED B/T/T / MAX / RED-DEUTSCH
-	-	-	-	-	-	-	-	-	-	-	-	-	-	-	A/R	37	02-03837541A5	SUB ASSY / LED WIDE ANGLE / AMB-AMB / DEUTSCH
-	-	-	-	-	-	-	-	-	-	-	-	-	-	-	A/R	38	02-03837541K5	SUB ASSY / LED WIDE ANGLE / RED-AMB / DEUTSCH
-	-	-	-	-	-	-	-	-	-	-	-	-	-	-	A/R	39	02-03837541R5	SUB ASSY / LED WIDE ANGLE / RED-RED / DEUTSCH
-	1	-	-	-	-	-	-	-	-	-	-	-	-	-	-	40	01-0283754-39	SUB ASSY / LED COMPARTMENT LIGHT
1	-	-	-	-	-	-	-	-	-	-	-	-	-	-	-	41	01-0283754-5N	SUB ASSY / LED B/T/T CERTIFIED - RED