

WHELEN[®] ENGINEERING COMPANY INC.

51 Winthrop Road
 Chester, Connecticut 06412-0684
 Phone: (860) 526-9504
 Fax: (860) 526-4078
 Internet: www.whelen.com
 Sales e-mail: autosale@whelen.com
 Canadian Sales e-mail: autocan@whelen.com
 Customer Service e-mail: custserv@whelen.com

Installation Guide: Model(s) SA340STS, SA340TS Siren Speaker

DANGER! Sirens produce extremely loud emergency warning tones! Exposure to these tones without proper and adequate hearing protection, could cause ear damage and/or hearing loss! The Occupational Safety & Health Administration (www.osha.gov) provides information necessary to determine safe exposure times in Occupational Noise Exposure Section 1910.95. Until you have determined the safe exposure times for your specific application, operators and anyone else in the immediate vicinity should be required to wear an approved hearing protection device. **FAILURE TO FOLLOW THIS RECOMMENDATION COULD CAUSE HEARING LOSS!**

Safety First

This document provides all the necessary information to allow your Whelen product to be properly and safely installed. Before beginning the installation and/or operation of your new product, the installation technician and operator must read this manual completely. Important information is contained herein that could prevent serious injury or damage.

- Proper installation of this product requires the installer to have a good understanding of automotive electronics, systems and procedures.
- If mounting this product requires drilling holes, the installer **MUST** be sure that no vehicle components or other vital parts could be damaged by the drilling process. Check both sides of the mounting surface before drilling begins. Also de-burr any holes and remove any metal shards or remnants. Install grommets into all wire passage holes.
- If this manual states that this product may be mounted with suction cups, magnets, tape or Velcro®, clean the mounting surface with a 50/50 mix of isopropyl alcohol and water and dry thoroughly.
- Do not install this product or route any wires in the deployment area of your air bag. Equipment mounted or located in the air bag deployment area will damage or reduce the effectiveness of the air bag, or become a projectile that could cause serious personal injury or death. Refer to your vehicle owner's manual for the air bag deployment area. The User/Installer assumes full responsibility to determine proper mounting location, based on providing ultimate safety to all passengers inside the vehicle.
- For this product to operate at optimum efficiency, a good electrical connection to chassis ground must be made. The recommended procedure requires the product ground wire to be connected directly to the **NEGATIVE (-)** battery post.
- If this product uses a remote device to activate or control this product, make sure this control is located in an area that allows both the vehicle and the control to be operated safely in any driving condition. **DO NOT ATTEMPT TO ACTIVATE OR CONTROL THIS DEVICE IN A HAZARDOUS DRIVING SITUATION.**
- It is recommended that these instructions be stored in a safe place and referred to when performing maintenance and/or reinstallation of this product.
- **FAILURE TO FOLLOW THESE SAFETY PRECAUTIONS AND INSTRUCTIONS COULD RESULT IN DAMAGE TO THE PRODUCT OR VEHICLE AND/OR SERIOUS INJURY TO YOU AND YOUR PASSENGERS!**

ACTIVATION OF THIS SIREN MAY DAMAGE UNPROTECTED EARS!



CAUTION

Loud siren noise can cause hearing damage and/or loss. Refer to OSHA Section 1910.95 prior to putting ANY siren into service!

For warranty information regarding this product, visit www.whelen.com/warranty

Selecting a Mounting Location: The mounting location should not only be as flat as possible to allow the speaker tone to be projected in a direction parallel with the road.

IMPORTANT! It is the responsibility of the installation technician to make sure that the installation and operation of this product will not interfere with or compromise the operation or efficiency of any vehicle equipment!

Caution: Permanent mounting of this product will require drilling. It is absolutely necessary to make sure that no other vehicle components could be damaged by this process. Check both sides of the mounting surface before starting. If damage is likely, select a different mounting location.

Fig. 2

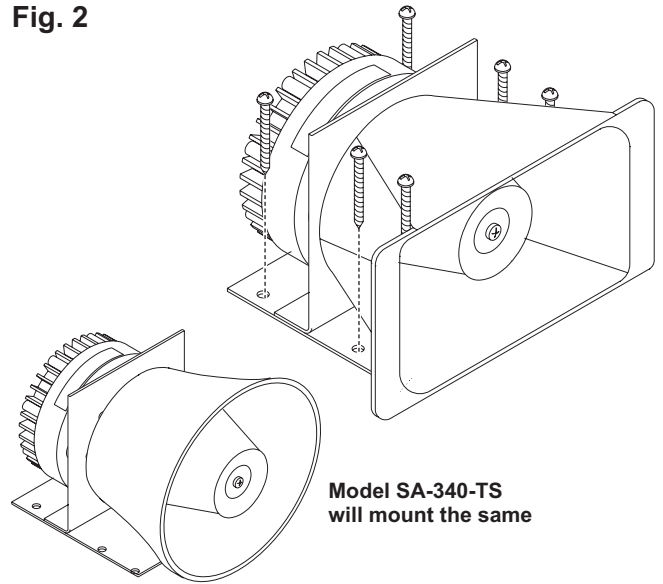
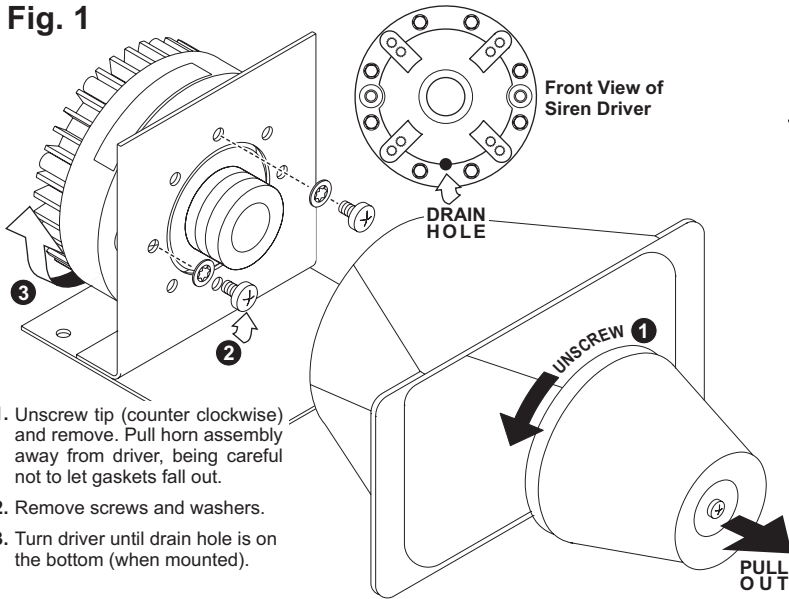

Fig. 1



1. Unscrew tip (counter clockwise) and remove. Pull horn assembly away from driver, being careful not to let gaskets fall out.
2. Remove screws and washers.
3. Turn driver until drain hole is on the bottom (when mounted).

Installation:

1. Position the bracket onto the desired mounting area and, using the bracket as a template, mark off the 6 mounting holes. **IMPORTANT!** Make sure that the drainage hole is located on the bottom of the siren after it is mounted. If the drainage hole will not be located correctly with the bracket mounted, loosen the driver and turn it so that the driver properly oriented (see Fig. 1).
2. Drill an appropriately sized hole into the mounting surface for each mounting screw location marked off in Step 1 (Fig. 2).
3. Secure the bracket onto the mounting surface with the customer supplied mounting hardware.
4. Extend the WHITE (Positive) and BLACK (Negative) speaker wires to your amplifier and connect as shown in the amplifier's instructions.

IMPORTANT! Before returning the vehicle to active service, confirm the proper operation of this product, as well as all vehicle components/equipment.

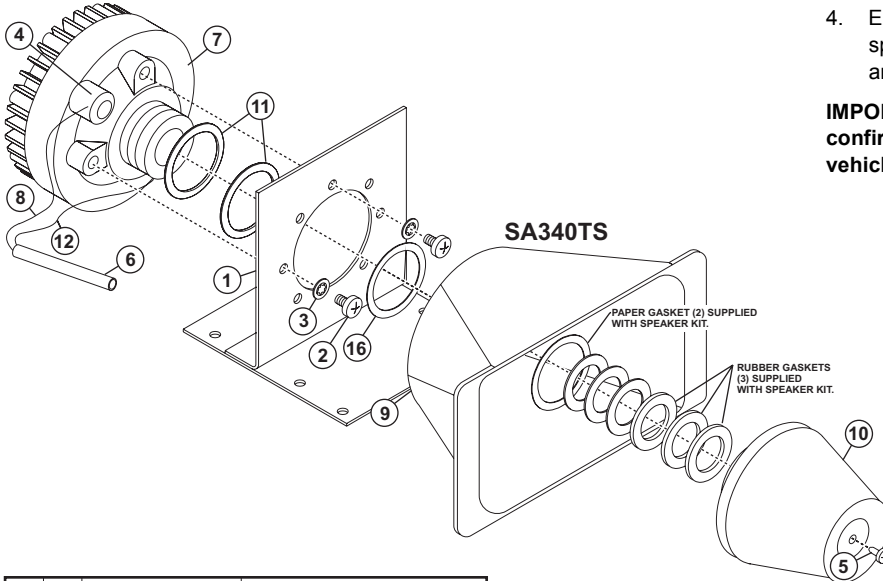

QTY	ITEM	PART NUMBER	DESCRIPTION
*		01-0881013-00C	MODEL SA-340-TS F/A
1	1	07-280414-010C	BRACKET-TWINSONIC FOR SD-500
4	2	14-130216-060C	1/4-20 X 3/8" PHMS
4	3	16-1321560-02C	1/4" INTERNAL L'WASHER
2	4	26-0716563-04	3/16" X 1" SHRINK TUBING
REF	5	15-081416-080	SCREW-#8 X 1/2" LG. PPHSMS
1	6	26-0610158-00C	PVC TUBING-BLACK 6" LG
1	7	43-0263146-00	DRIVER SANMING 100W SD-210R
1	8	67-1361699150	1/C 16 GA. WIRE WHT 15" LG. W/FSTN
1	9	72-3180579-00C	FLARE-TWINSONIC
1	10	72-4010291-00	TIP SA510-M1
2	11	38-0220047-00	METAL GASKET
1	12	67-1361600150	1/C 16 GA. WIRE BLK. 15" LG. W/FSTN

QTY	ITEM	PART NUMBER	DESCRIPTION
*		01-0861413-00	SA-340-TS
1	1	15-081416-080	8 x 1/2" PPHSMS
1	2	72-4010291-00	TIP-SA510-M1
1	3	72-1040522-06	SPEAKER BELL SA-974
4	4	38-0220047-00	METAL GASKET
1	5	43-0263146-00	DRIVER SANMING 100W SD-210R
1	6	07-280414-010	BRACKET
4	7	16-1321560-02	1/4" INT. TOOTH WASHER
4	8	14-130216-060	1/4"-20 x 3/8" PPHMS
2	9	26-0716563-04	3/16" X 1" SHRINK TUBING
1	10	67-1361600150	16 GA BLK 15" (1) FASTON
1	11	26-0610158-00	PVC TUBE 6" BLK
1	12	67-1361699150	16 GA 15" (1) FASTON

