

51 Winthrop Road  
Chester, Connecticut 06412-0684  
Phone: (860) 526-9504  
Fax: (860) 526-4078  
Sales Email: autosale@whelen.com  
Canadian Sales: autocan@whelen.com  
Customer Service: custserv@whelen.com

#### Safety First

This document provides all the necessary information to allow your Whelen product to be properly and safely installed. Before beginning the installation and/or operation of your new product, the installation technician and operator must read this manual completely. Important information is contained herein that could prevent serious injury or damage.

- Proper installation of this product requires the installer to have a good understanding of automotive electronics, systems and procedures.
- If mounting this product requires drilling holes, the installer **MUST** be sure that no vehicle components or other vital parts could be damaged by the drilling process. Check both sides of the mounting surface before drilling begins. Also de-burr any holes and remove any metal shards or remnants. Install grommets into all wire passage holes.
- Do not install this product or route any wires in the deployment area of your air bag. Equipment mounted or located in the air bag deployment area will damage or reduce the effectiveness of the air bag, or become a projectile that could cause serious personal injury or death. Refer to your vehicle owner's manual for the air bag deployment area. The User/Installer assumes full responsibility to determine proper mounting location, based on providing ultimate safety to all passengers inside the vehicle.
- For this product to operate at optimum efficiency, a good electrical connection to chassis ground must be made. The recommended procedure requires the product ground wire to be connected directly to the **NEGATIVE (-)** battery post.
- If this product uses a remote device to activate or control this product, make sure that this control is located in an area that allows both the vehicle and the control to be operated safely in any driving condition.
- Do not attempt to activate or control this device in a hazardous driving situation.
- This product contains either strobe light(s), halogen light(s), high-intensity LEDs or a combination of these lights. Do not stare directly into these lights. Momentary blindness and/or eye damage could result.
- Use only soap and water to clean the outer lens. Use of other chemicals could result in premature lens cracking (crazing) and discoloration. Lenses in this condition have significantly reduced effectiveness and should be replaced immediately. Inspect and operate this product regularly to confirm its proper operation and mounting condition. Do not use a pressure washer to clean this product.
- **WARNING!** All customer supplied wires that connect to the positive (+) terminal of the battery must be sized to supply at least 125% of the maximum operating current and **FUSED** "at the battery" to carry that load. **DO NOT USE CIRCUIT BREAKERS WITH THIS PRODUCT!**
- **FAILURE TO FOLLOW THESE PRECAUTIONS AND INSTRUCTIONS COULD RESULT IN DAMAGE TO THE PRODUCT OR VEHICLE AND/OR SERIOUS INJURY TO YOU AND YOUR PASSENGERS!**

**CAUTION!** This product has been designed to rest on top of the vehicle's dashboard. Suction cups are provided to prevent lateral movement while the vehicle is in motion. These suction cups should not be used to suspend this product above the dashboard. Clean suction cup mounting surface thoroughly before mounting.

**IMPORTANT!** It is the responsibility of the installation technician to make sure that the installation and operation of this product will not interfere with or compromise the operation or efficiency of any vehicle equipment!

Before returning the vehicle to active service, visually confirm the proper operation of this product, as well as all vehicle components and/or equipment.

**IMPORTANT!** The light output of this product should be projected parallel to the road.

**NOTE:** The cigar cord adaptor is equipped with an 8 Amp Fuse. If the fuse must ever be replaced, be sure to use one with an identical value.

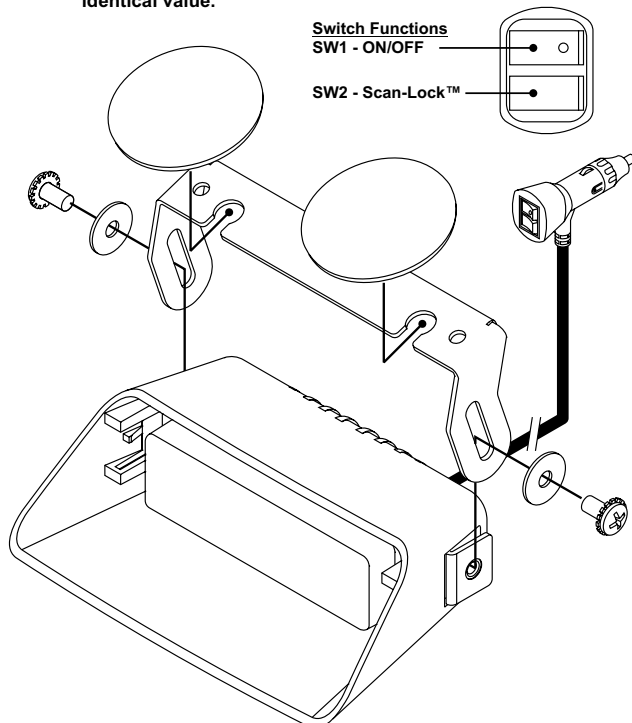

**TO CYCLE FORWARD**, press the Scan-Lock™ button for less than 1 second and release.

**TO CYCLE BACKWARDS**, press the Scan-Lock™ button for more than 1 second and release.

**TO RESTORE FACTORY DEFAULT**, turn the power to the unit off. Press and hold the Scan-Lock™ button while turning the power on. Allow this pattern to run for at least 5 seconds to complete the selection.

#### Flash Patterns:

**NOTE:** **BOLD** = California Title XIII Compliant Pattern

- |                           |                            |
|---------------------------|----------------------------|
| 1. SignalAlert™ 75        | <b>15. SingleFlash 60</b>  |
| 2. SignalAlert™ 75*       | <b>16. SingleFlash 90</b>  |
| 3. CometFlash® 75         | <b>17. SingleFlash 120</b> |
| 4. CometFlash® 75*        | 18. SingleFlash 300        |
| <b>5. DoubleFlash 75</b>  | 19. DoubleFlash 150        |
| <b>6. DoubleFlash 75*</b> | 20. ComAlert™ 150          |
| <b>7. SingleFlash 75</b>  | 21. ActionFlash™ 50        |
| <b>8. SingleFlash 75*</b> | 22. ActionFlash™ 150       |
| 9. ComAlert™ 75           | 23. ModuFlash™             |
| 10. ComAlert™ 75*         | 24. ActionScan™            |
| 11. LongBurst™ 75         | <b>25. Steady</b>          |
| 12. LongBurst™ 75*        |                            |
| <b>13. PingPong™ 75</b>   |                            |
| <b>14. PingPong™ 75*</b>  |                            |

\* in this application, this pattern is visually indistinguishable from the identically-named pattern.