

# WHELEN<sup>®</sup>

ENGINEERING COMPANY INC.

51 Winthrop Road  
Chester, Connecticut 06412-0684  
Phone: (860) 526-9504  
Fax: (860) 526-4078  
Internet: [www.whelen.com](http://www.whelen.com)  
Sales e-mail: [autosale@whelen.com](mailto:autosale@whelen.com)  
Canadian Sales e-mail: [canadiansales@whelen.com](mailto:canadiansales@whelen.com)  
Customer Service e-mail: [custserv@whelen.com](mailto:custserv@whelen.com)

## Installation Guide: Pioneer™ LED Floodlight (Bail Mount)

### Safety First

This document provides all the necessary information to allow your Whelen product to be properly and safely installed. Before beginning the installation and/or operation of your new product, the installation technician and operator must read this manual completely. Important information is contained herein that could prevent serious injury or damage.

- **Proper installation of this product requires the installer to have a good understanding of automotive electronics, systems and procedures.**
- **Failure to use specified installation parts and/or hardware will void the product warranty!**
- **If mounting this product requires drilling holes, the installer MUST be sure that no vehicle components or other vital parts could be damaged by the drilling process. Check both sides of the mounting surface before drilling begins. Also de-burr any holes and remove any metal shards or remnants. Install grommets into all wire passage holes.**
- **If this manual states that this product may be mounted with suction cups, magnets, tape or Velcro®, clean the mounting surface with a 50/50 mix of isopropyl alcohol and water and dry thoroughly.**
- **Do not install this product or route any wires in the deployment area of your air bag. Equipment mounted or located in the air bag deployment area will damage or reduce the effectiveness of the air bag, or become a projectile that could cause serious personal injury or death. Refer to your vehicle owner's manual for the air bag deployment area. The User/Installer assumes full responsibility to determine proper mounting location, based on providing ultimate safety to all passengers inside the vehicle.**
- **For this product to operate at optimum efficiency, a good electrical connection to chassis ground must be made. The recommended procedure requires the product ground wire to be connected directly to the NEGATIVE (-) battery post.**
- **If this product uses a remote device to activate or control this product, make sure that this control is located in an area that allows both the vehicle and the control to be operated safely in any driving condition.**
- **Do not attempt to activate or control this device in a hazardous driving situation.**
- **This product contains either strobe light(s), halogen light(s), high-intensity LEDs or a combination of these lights. Do not stare directly into these lights. Momentary blindness and/or eye damage could result.**
- **Use only soap and water to clean the outer lens. Use of other chemicals could result in premature lens cracking (crazing) and discoloration. Lenses in this condition have significantly reduced effectiveness and should be replaced immediately. Inspect and operate this product regularly to confirm its proper operation and mounting condition. Do not use a pressure washer to clean this product.**
- **It is recommended that these instructions be stored in a safe place and referred to when performing maintenance and/or reinstallation of this product.**
- **FAILURE TO FOLLOW THESE SAFETY PRECAUTIONS AND INSTRUCTIONS COULD RESULT IN DAMAGE TO THE PRODUCT OR VEHICLE AND/OR SERIOUS INJURY TO YOU AND YOUR PASSENGERS!**

**For warranty information regarding this product, visit [www.whelen.com/warranty](http://www.whelen.com/warranty)**

This manual will outline bail bracket installation procedures for the Pioneer-series light. With the exception of the Micro Pioneer, all of the bail bracket mounting kits use identical hardware to secure the bracket to its mounting surface. Refer to Page 3 for information on mounting the Micro Pioneer.

**Mounting...**

**CAUTION: Mounting this product will require drilling. It is absolutely necessary to make sure that no other vehicle components could be damaged by this process. Check both sides of the mounting surface before starting. If damage is likely, select a different mounting location.**

1. Position the appropriate bail bracket (Item #5) onto the proposed mounting surface. Mark the areas where the mounting holes are to be drilled.
2. Drill the mounting holes required using an appropriately sized drill bit (refer to the Mounting Hole Specifications shown below).

**IMPORTANT NOTE! This installation uses Rivnuts to secure the brackets to the vehicle. This type of hardware requires the use of a specialized installation tool. Refer to the owners manual included with this tool for proper installation techniques. Be sure to follow the mounting hole specifications precisely!**

3. With the Rivnuts properly installed, position the appropriate seal (#9) over the mounting holes and position the mounting bracket onto the seal. The bracket can now be mounted onto the vehicle using the appropriate hardware (Items #2, #3 & #4). Insert the bolts into their holes with the hardware shown.
4. Apply a drop of LocTite 242 to each of the mounting bolts and insert them into their Rivnut. Tighten each bolt to 50 in/lbs.
5. Insert the two brass hex nuts (Item(s) #1) into the cavity provided in the rear of the Pioneer housing. Now position the Pioneer housing into its mounted position on the bail bracket. Using the hardware provided (Items #6, #7 & #8) secure the housing assembly onto the bail bracket.
6. Adjust the floodlight to the desired angle and tighten the hardware firmly to maintain that angle (minimum 20 foot-pounds)
7. Extend the Pioneer wires towards it's designated power source. Make the necessary connections using the information found in the following section.

**Wiring...**

Refer to the wiring guide included with your Pioneer for wire functions, fuse values and optional switch connections.

**IMPORTANT! Before returning the vehicle to active service, visually confirm the proper operation of this product, as well as all vehicle components/equipment.**

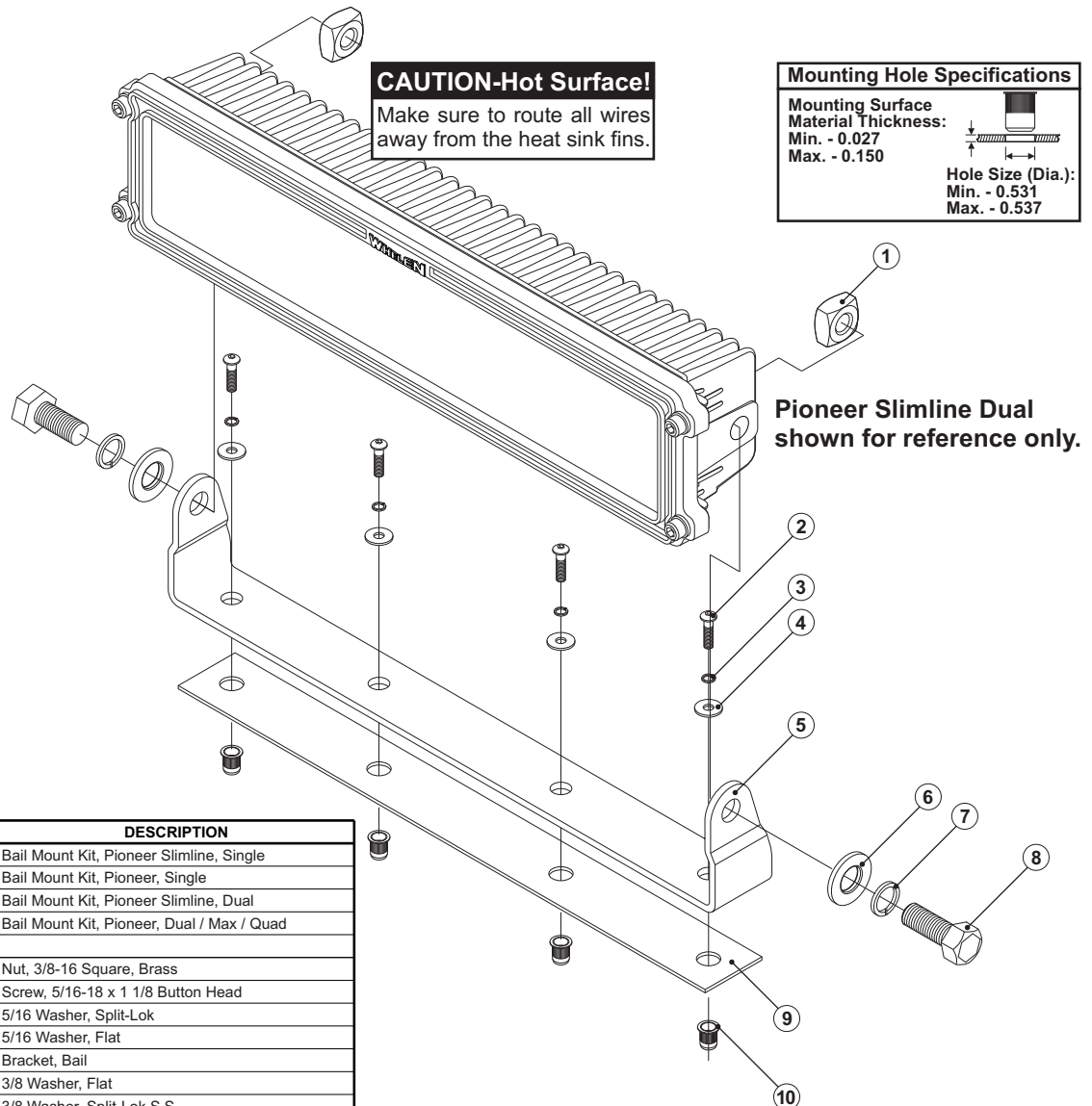

QTY	QTY	QTY	QTY	ITEM	DESCRIPTION
		*			Bail Mount Kit, Pioneer Slimline, Single
		*			Bail Mount Kit, Pioneer, Single
	*				Bail Mount Kit, Pioneer Slimline, Dual
*					Bail Mount Kit, Pioneer, Dual / Max / Quad
2	2	2	2	1	Nut, 3/8-16 Square, Brass
4	4	3	3	2	Screw, 5/16-18 x 1 1/8 Button Head
4	4	3	3	3	5/16 Washer, Split-Lok
4	4	3	3	4	5/16 Washer, Flat
1	1	1	1	5	Bracket, Bail
2	2	2	2	6	3/8 Washer, Flat
2	2	2	2	7	3/8 Washer, Split-Lok S.S.
2	2	2	2	8	Screw, 3/8 X 1 1/4 Hex S.S.
1	1	1	1	9	Seal
4	4	3	3	10	5/16 - 18 Riv Nut

**CAUTION: Mounting this product will require drilling. It is absolutely necessary to make sure that no other vehicle components could be damaged by this process. Check both sides of the mounting surface before starting. If damage is likely, select a different mounting location.**

**Mounting (Micro & Nano Pioneer)...**

1. Position the bail bracket (Item #11) onto the proposed mounting surface. Mark the areas where the mounting hole is to be drilled.
2. Drill the required mounting hole using an appropriately sized drill bit.
3. Secure the bail bracket to the mounting surface as shown using the mounting hardware provided (Items #7, #10 & #11).
4. Insert the two brass hex nuts (Item(s) #6) into the cavity provided in the rear of the Micro Pioneer housing. Now position the Micro Pioneer housing into its mounted position on the bail bracket. Using the hardware provided (Items #7, #8 & #9) secure the housing assembly onto the bail bracket.
5. Adjust the floodlight to the desired angle and tighten the hardware firmly to maintain that angle.
6. Extend Pioneer cable towards its designated power source. Make the necessary connections using the information found in the wiring guide.

**Wiring...**

Refer to the wiring guide included with your Pioneer for wire functions, fuse values and optional switch connections.

**IMPORTANT! Before returning the vehicle to active service, visually confirm the proper operation of this product, as well as all vehicle components/equipment.**

**Lens Replacement (Micro, Slimline & Nano Series)...**

1. Remove the screw and washers (items 1 and 2) that secure the retainer to the Pioneer housing.
2. Remove the retainer and the lens (items 3 and 4) from the housing.
3. Before installing the new lens, make sure the gasket (item 5) is fully seated in the housing and is not distorted, twisted or deformed in any way.
4. Place the new lens onto the housing. Note: Be sure any text or the Whelen logo on the lens is properly orientated. Return the retainer to its original position and secure using the hardware removed in step 1.

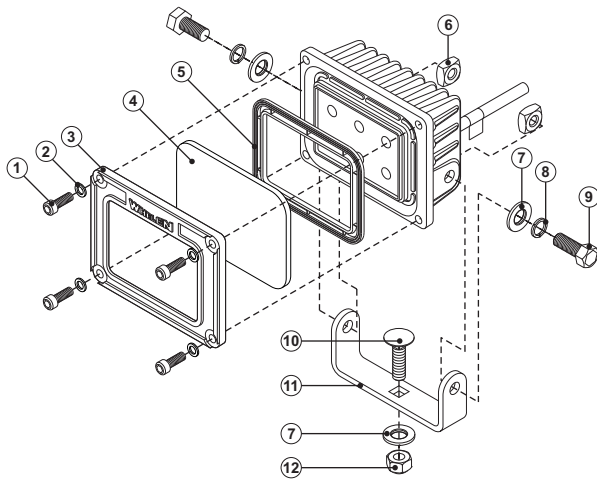

QTY	ITEM	DESCRIPTION
		Nano Pioneer™ Bail Mount Kit
4	1	Screw, 8-32 X 1/2" Socket Head Cap
4	2	Washer, Flat, Nylon, .175 ID x .281 OD x .031
1	3	Retainer
1	4	Lens
1	5	Gasket, Lens
2	6	Nut, 1/4-20 Square, Brass
3	7	Washer, Flat 1/4"
2	8	Washer, Split-Lok 1/4"
2	9	Screw, 1/4-20 X 3/4" S.S.
1	10	Bolt, 1/4-20 x 3/4" Carriage
1	11	Bracket, Bail Mount
1	12	Nut, 1/4-20 Elastic Stop

QTY	ITEM	DESCRIPTION
		Micro Pioneer™ Bail Mount Kit
4	1	Screw, 10-24 X .625, Socket Head Cap
4	2	Washer, Flat, Nylon, .188 ID x .3438 OD x .050
1	3	Retainer
1	4	Lens
1	5	Gasket, Lens
2	6	Nut, 3/8-16 Square, Brass
3	7	Washer, 3/8 Flat S.S.
2	8	Washer, 3/8 Split-Lok S.S.
2	9	Screw, 3/8 X 1 1/4 Hex S.S.
1	10	Bolt, 3/8 - 16 x 1 3/4, Carriage
1	11	Bracket, Bail Mount
1	12	Nut, 3/8-16 Elastic Stop

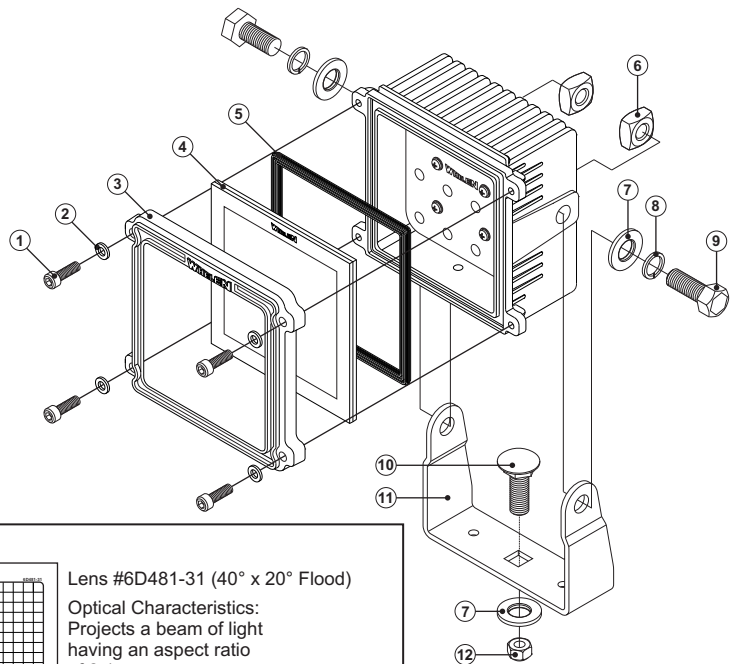

**Accessory Lenses**

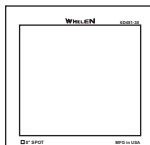

Lens #6D481-30 (8° Spot)  
 Optical Characteristics:  
 Projects a beam of light having an aspect ratio of 1:1 (Square)  
 Example:

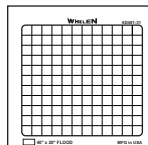

Lens #6D481-31 (40° x 20° Flood)  
 Optical Characteristics:  
 Projects a beam of light having an aspect ratio of 2:1  
 Example:

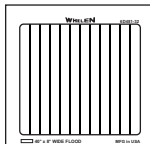

Lens #6D481-32 (40° x 8° Wide Flood)  
 Optical Characteristics:  
 Projects a beam of light having an aspect ratio of 5:1  
 Example:

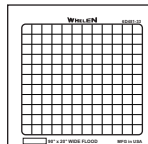

Lens #6D481-33 (90° x 20° Wide Flood)  
 Optical Characteristics:  
 Projects a beam of light having an aspect ratio of 9:2  
 Example: