

**Safety First:** This document provides all the necessary information to allow your Whelen product to be properly and safely installed. Before beginning the installation and/or operation of your new product, the installation technician and operator must read this manual completely. Important information is contained herein that could prevent serious injury or damage.

- Proper installation of this product requires the installer to have a good understanding of automotive electronics, systems and procedures.
- Whelen Engineering requires the use of waterproof butt splices and/or connectors if that connector could be exposed to moisture.
- Failure to use specified installation parts and/or hardware will void the product warranty!
- If mounting this product requires drilling holes, the installer **MUST** be sure that no vehicle components or other vital parts could be damaged by the drilling process. Check both sides of the mounting surface before drilling begins. Also de-burr any holes and remove any metal shards or remnants. Install grommets into all wire passage holes.
- Do not install this product or route any wires in the deployment area of your air bag. Equipment mounted or located in the air bag deployment area will damage or reduce the effectiveness of the air bag, or become a projectile that could cause serious personal injury or death. Refer to your vehicle owner's manual for the air bag deployment area. The User/Installer assumes full responsibility to determine proper mounting location, based on providing ultimate safety to all passengers inside the vehicle.
- For this product to operate at optimum efficiency, a good electrical connection to chassis ground must be made. The recommended procedure requires the product ground wire to be connected directly to the **NEGATIVE (-)** battery post.
- Do not attempt to activate or control this device in a hazardous driving situation.
- If this product uses a remote device to activate or control this product, make sure that this control is located in an area that allows both the vehicle and the control to be operated safely in any driving condition.
- This product contains either strobe light(s), halogen light(s), high-intensity LEDs or a combination of these lights. Do not stare directly into these lights. Momentary blindness and/or eye damage could result.
- Use only soap and water to clean the outer lens. Use of other chemicals could result in premature lens cracking (crazing) and discoloration. Lenses in this condition have significantly reduced effectiveness and should be replaced immediately. Inspect and operate this product regularly to confirm its proper operation and mounting condition. Do not use a pressure washer to clean this product.
- **WARNING!** All customer supplied wires that connect to the positive (+) terminal of the battery must be sized to supply at least 125% of the maximum operating current and **FUSED** "at the battery" to carry that load. **DO NOT USE CIRCUIT BREAKERS WITH THIS PRODUCT!**
- **FAILURE TO FOLLOW THESE PRECAUTIONS AND INSTRUCTIONS COULD RESULT IN DAMAGE TO THE PRODUCT OR VEHICLE AND/OR SERIOUS INJURY TO YOU AND YOUR PASSENGERS!**

**Mounting:**

**NOTE: The dual Avenger is shown for reference only.**

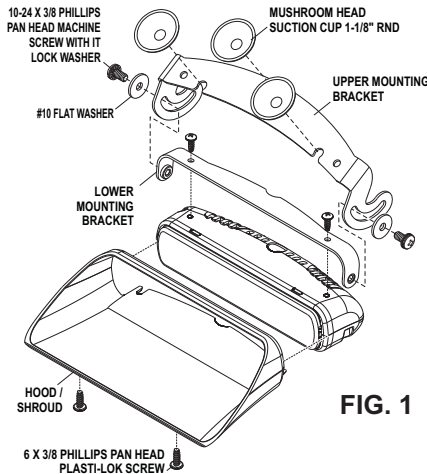

**FIG. 1**

**CAUTION!** Nighttime operation of this product may produce reflected light within the vehicle! Use with caution!

**CAUTION:** This product has been designed to rest on top of the vehicle dashboard. Suction cups are used to prevent lateral movement while the vehicle is in motion. These suction cups should not be used to suspend this product above the dashboard.

1. Secure the lower mounting bracket to the Avenger II®.
2. Slide the suction cups onto the upper mounting bracket and secure the upper mounting bracket onto the lower mounting bracket.
3. Secure the visor hood to the unit.
4. With the Avenger II resting on the top of the dashboard, apply the suction cups to the windshield. **Do not locate the Avenger II in any location where it will interfere with the drivers ability to safely operate the vehicle. Refer to the safety warnings on the cover of this manual.**
5. Adjust the angle of the Avenger II bracket until the visor hood is in full contact with the windshield.

There are holes on the bail strap bracket to be used if permanent mounting is desired. Using the bail strap bracket as a template, mark the areas where the mounting holes are to be drilled. Secure the unit using the appropriate hardware (customer supplied).

**Wiring:**

**IMPORTANT AIR BAG WARNING!** Do not install this product or route any wires in the air bag deployment zone of your vehicle. Equipment mounted or located in air bag deployment zones will damage or reduce the effectiveness of the air bag, or become a projectile that could cause serious personal injury or death. Refer to your vehicle owners manual to learn the air bag deployment zones for the vehicle. The User/Installer assumes full responsibility to determine proper mounting location, based on providing ultimate safety to all passengers inside the vehicle.

The Avenger II uses a cigar cord for power. No further wiring is required.

**FIG. 2**

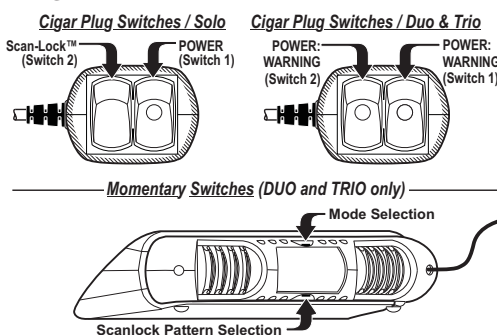

**Operation: SOLO**

**Switch 1: Activates Warning.**

- Default Pattern: SignalAlert CA

**Switch 2: Scan-Lock Flash Pattern Selection**

**Operation: DUO**

**Switch 1: Activates Color 1 Warning:**

- Default flash pattern: SignalAlert CA
- Select from available flash patterns. (Steady Pattern will only work if a single color MODE is active.)

**Switch 2: Activates Color 2 Warning:**

- Default flash pattern: SignalAlert 75 CA
- Switch 2 overrides CIGAR SWITCH 1.
- Select from available flash patterns. (Steady Pattern only is enabled if a single color MODE is active)

**NOTE: There are two push buttons located on light for mode and flash pattern selection.**

**Operation TRIO:**

**Switch 1: Activates Color 1 and 2 Warning:**

- Default flash pattern: SignalAlert CA
- Select from available flash patterns. (Steady Pattern will only work if a single color MODE is active.)

**Switch 2: Activates Color 3 Steady:**

- Default flash pattern: Steady.
- CIGAR SWITCH 2 over-rides CIGAR SWITCH 1.
- Select from available flash patterns. (Steady Pattern will only work if a single color MODE is active.)
- Mode switch cycles through available modes. Each mode can be preset with its own flash pattern.

**NOTE: There are two push buttons located on light for mode and flash pattern selection.**

**Mode switch cycles through available modes. Press and release to advance to the next mode:**

- |                             |                                |
|-----------------------------|--------------------------------|
| <b>MODE 1:</b> Color 1      | <b>MODE 5:</b> Colors 1 & 3    |
| <b>MODE 2:</b> Color 2      | <b>MODE 6:</b> Colors 2 & 3    |
| <b>MODE 3:</b> Colors 3     | <b>MODE 7:</b> Colors 1, 2 & 3 |
| <b>MODE 4:</b> Colors 1 & 2 |                                |

**ScanLock™ Pattern Selection:**

To advance to the next flash pattern, press the ScanLock button for less than 1 second. To cycle backwards to previous patterns, press the ScanLock button for more than 1 second.

To reset to the factory default pattern: With power to the light off, press and hold the ScanLock button. Turn the light on and keep the ScanLock button depressed for at least 5 seconds before releasing.

**Pattern List**

- |                      |                              |
|----------------------|------------------------------|
| 1. SignalAlert CA*   | 16. TripleFlash 120*         |
| 2. CometFlash®       | 17. ActionScan 50            |
| 3. DoubleFlash 75*   | 18. ActionFlash 150          |
| 4. SingleFlash 75*   | 19. SignalAlert 75           |
| 5. ComAlert™ 75      | 20. Action/Single 60/120*    |
| 6. LongBurst™ 75*    | 21. Action/Single 120/TF 75* |
| 7. PingPong™ 75      | 22. CalScan*                 |
| 8. SingleFlash 60*   | 23. ModuFlash                |
| 9. SingleFlash 90*   | 24. ActionScan               |
| 10. SingleFlash 120* | 25. CometFlash CA*           |
| 11. SingleFlash 300* | 26. Steady*                  |
| 12. DoubleFlash 120* |                              |
| 13. ComAlert™ 150    |                              |
| 14. PingPong 120*    |                              |
| 15. TripleFlash 75*  |                              |

\* = CA Title XIII Compliant

**Default Patterns:**

- SOLO - SignalAlert CA
- DUO - SignalAlert CA
- TRIO - COLORS 1 & 2 alternate with SignalAlert CA. COLOR 3 is Steady

**IMPORTANT WARNING!**

**CAUTION! DO NOT LOOK DIRECTLY AT THESE LEDS WHILE THEY ARE ON. MOMENTARY BLINDNESS AND/OR EYE DAMAGE COULD RESULT!**