

900 Lumen LED Worklight

4.6" SQUARE W/ U-BRACKET

#EWLF0900SBDF0W (Flood)

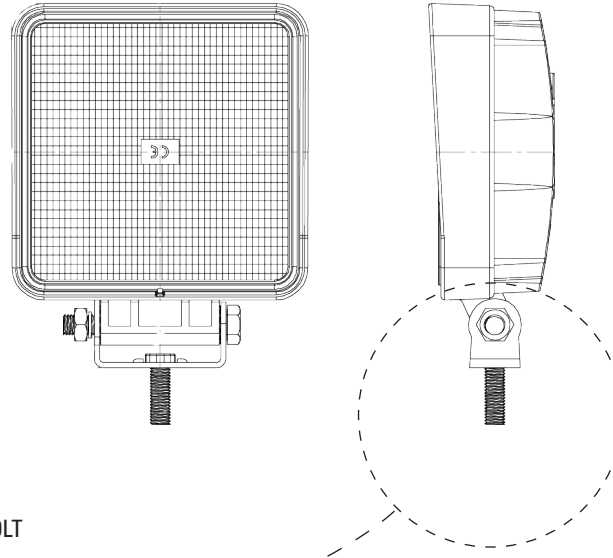
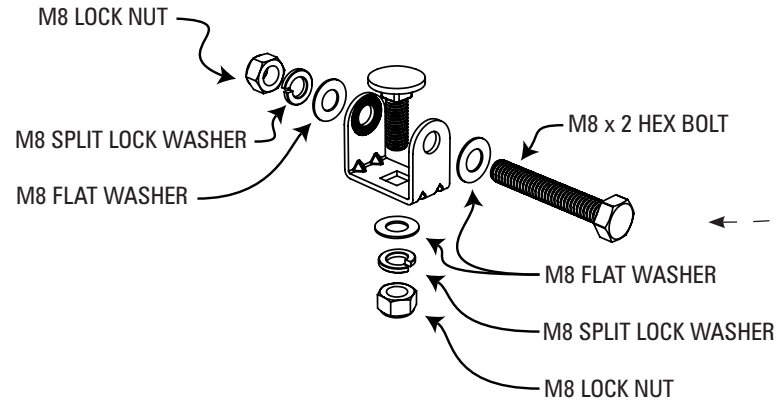

ELECTRICAL CONNECTIONS:

See diagram below for required electrical connections. Connect the WHITE wire to +9-33 Vdc through a customer supplied 5A fuse and switch. Connect the BLACK wire to a reliable ground.

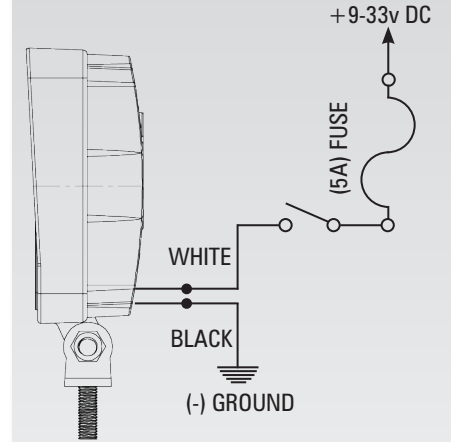

MECHANICAL ATTACHMENT:

Assemble Mounting bracket as shown in the diagram to the left. All bolts should be torqued to a maximum of 25 in-lbs.



TECHNICAL SPECIFICATIONS

Overall Dimensions:	5.67"H x 4.63"W x 1.97"D
Input Voltage Range:	9-33Vdc
Current Draw:	1.45 Amps @ 12.8 Vdc, 0.70 Amps @ 25.6 Vdc
Wattage:	18 Watts
Reverse Polarity:	Protected
Load Dump:	Protected
Operating Temperature:	-40° to +65° C
Optical Distribution:	Flood
Color Temperature:	5000 - 6000K
Number of LEDs:	9



To review our Limited Warranty Statement & Return Policy for this or any SoundOff Signal product please visit our website at www.soundoffsignal.com and select the "Warranty & Returns" link along the left column of our home page. If you have questions regarding this product please contact Technical Services, Monday - Friday, 8 am to 5 pm at 1.800.338.7337, press #4 to skip the automated message. Questions or comments that do not require immediate attention may be emailed to techsupport@soundoffsignal.com.

1.800.338.7337. / www.soundoffsignal.com / Thank you for trusting us with your safety!